



SM35AWB Wireless load Displacement Transducer



一、 Introduction

SM35AWB Wireless load sensor is for rod-pumped well testing and design diagrams, set the load displacement and acceleration measurement (optional), low power consumption embedded microcontroller, low-power wireless digital communication technology in the integration of high-performance wireless sensor products, oil and gas production is the digital oilfield construction of Internet of things one of the most important front-end acquisition device. With the support of acceleration sensor and angular displacement sensor, it synchronizes the online measurement of the suspended point load and the optical rod displacement of the pumping unit periodically, and realizes the telemetry of the power diagram data that represents the working conditions of the pumping unit well through the remote transmission of the local wireless data communication network.

The high reliability design adapted to the industrial environment, as well as the characteristics of high precision, simple installation, convenient maintenance, environmental protection and durability have won the recognition of users, not only in domestic Shengli, Daqing, North China, Changqing, Xinjiang, Qinghai and other major oil fields have been promoted and applied, but also in overseas oil companies.

二、 Feature

- Automatic acquisition,
- Extended measurement,
- Various power supply,
- Wireless system,
- Dense acquisition and low power consumption design,
- Reliable installation,
- Remote maintenance

.....
Dimensions (In mm. 1mm=0.03937 inches)

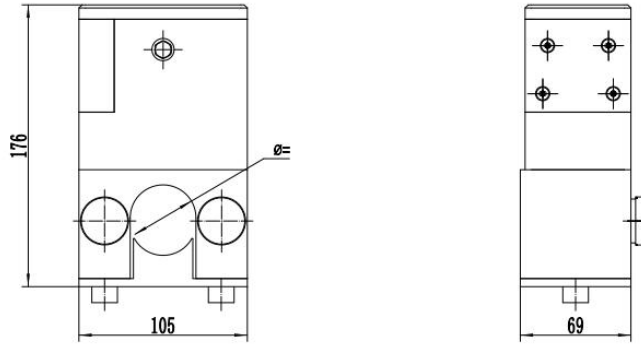

Circuit Diagram :

Two-wire system: power supply + : red power supply -: black

two-wire system: EXC+: red EXC-: black

	50KN	Φ 40
	100KN	Φ 40
110235AWBF1508	150KN	Φ 40
	180KN	Φ 40
	200KN	Φ 40
	250KN	Φ 40
110235AWBF120835	150KN	Φ 35
110235AWBF180845	150KN	Φ 45

Specification :

Type	Technical parameters	
Measuring range	0-150KN	
Communication protocol	ZigBee & WAI-PA	
Comprehensive precision	0.5%FS	
stability	±0.1%FS/year	
Communication distance	≥300m	
Working voltage	Lithium - thionyl chloride high energy disposable battery, 3.6V/38Ah Lithium - thionyl chloride high energy disposable battery 3.6V/38Ah	
Working temperature	-40 ~ +85°C	
Allow overload	150%F.S	
Insulation resistance	≥5000MΩ	
Protection grade	IP68 (IEC60529)	