



SUNMOON
日月科技

SMA35GDDC-B 载荷传感器

SMA35GDDC-B Load Transducer

一、概述 Summarize

有线载荷传感器，是一款具有高抗干扰性能的载荷传感器。产品采用标准电流 4-20mA 信号输出以及全密封设计，可工作在高温、高寒、高湿、高辐射等恶劣环境，目前广泛应用于抽油机功图测量系统中。

The wired load sensor is a load sensor with high anti-interference performance. The product adopts standard current 4-20mA signal output and fully sealed design, can work in high temperature, high cold, high humidity, high radiation and other harsh environment, and is widely used in the power diagram measurement system of pumping units.

二、特点 Characteristic

- 1、经过全国各个油田二十年的使用，不断完善；
- 2、全密封防水设计，满足全天候使用；
- 3、优化接线端子，提高可靠性；
- 4、操作方便安全；
- 5、标准 4~20mA 二线制输出；
- 6、供电不分正负极；

- 1.After 20 years of use of various oil fields in the country, continuous improvement.
- 2.Fully sealed waterproof design, to meet all-weather use;
- 3.Optimize terminal, improve reliability;
- 4.Easy to operate and safe;
- 5.Standard 4 ~ 20mA two-wire system output;
- 6.The power supply is not positive and negative;



.....
Dimensions 外形尺寸 (In mm. 1mm=0.03937 inches)

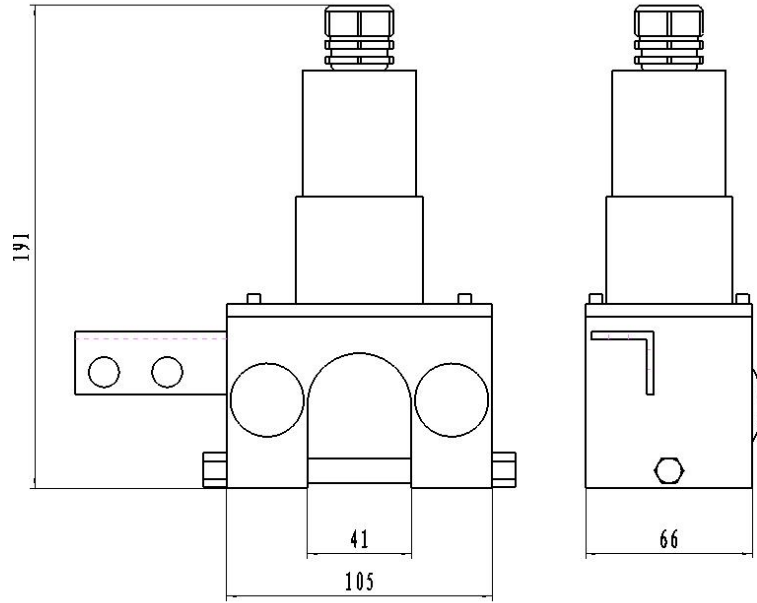

Circuit Diagram 电路图:

两线制输出: 供电不分正负极

Two-wire output: no positive or negative power supply

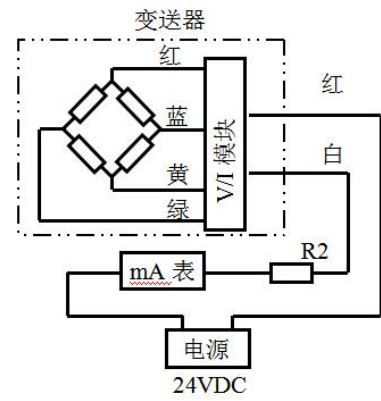



Specification 技术参数:

项目 Type	技术参数 Technical parameters
测量范围 Nominal load range	0 ~ 150 KN
输出 output	4-20mA
综合精度 Class precision	0.5%FS
绝缘电阻 Insulation Resistance	$\geq 5000M\Omega$
零点输出 Zero Balance	$\leq 0.1\%FS$
工作电压 Power supply	15~24 VDC
温度漂移 Effect of temperature	0.5%FS/10°C
温度补偿 temperature compensation	-10~65°C
工作温度 Operating temperature	-40 ~ +85°C
安全过载 Safe Load Limit	150% FS
本体塑变极限 Safety margin against yielding	300% FS
材质 Material material	高性能合金钢或（铬比大于 15%不锈钢） High performance alloy steel or (chromium ratio>15% stainless steel)
防护等级 Protection type	IP68 (IEC60529)